

GRUN THE
GRUN
COMPANY

WWW.GRUNCOMPANY.COM

HM550J HYDROMULCHER

WHY BUY?

High impact poly resin tank will not corrode – reduces maintenance costs & extends equipment life.

Powder coat paint – twice as durable as liquid paint when pressure washed.

Recirculation port – reduces clogs, makes mixing faster & makes cleaning easier.

Heavy gauge steel throughout – compare vs competition.

Optional mulch grinder – makes mixing faster and reduces clogs.

Loading platform – holds mulch bale and additives for quicker & easier loading.

Compact footprint – plumbing protected under the tank.

Reinforced steel bands – securely holds tank in place, extending the life of the equipment.

Manufactured in a high-precision military supplier facility.



PLEASE CALL GRUN OR YOUR LOCAL DEALER FOR MORE INFORMATION, OR VISIT OUR WEBSITE.

WWW.GRUNCOMPANY.COM

T 209.577.1430

HM550J HYDROMULCHER

PRODUCT OVERVIEW

GRUN HM550J - TECHNICAL SPECIFICATIONS (SKID MODEL)

Agitation	Jet
Battery	12 v
Brakes	Electric standard, hydraulic surge optional
Coverage per tank load	7,300 sq ft (678 sq meters)
Discharge distance (hose)	70' (21 meters)
Engine.....	Honda 13hpES
Engine safety system	Low oil pressure shut off
Fuel tank capacity	1.6 gallons (6.1 liters)
Height	56" (1396 mm)
Hose	50' length of 1 1/4" semi-rigid 250psi rubber hose with quick disconnect nozzles
Hose reel.....	Optional
Length	119" (3022 mm)
Loading platform.....	Standard
Maximum material capacity	200 lbs. (90 kg.)
Mulch grinder.....	Optional
Nozzles	1 long distance, 1 large fan, 1 small fan
Pump	Monarch 3"x3" centrifugal
Pump drive	Direct drive
Recirculation port	Standard
Tank	550 gallon (2082 liters) non-corrosive high impact poly resin tank
Weight - empty.....	1,100 lbs (499 kg)
Weight - loaded.....	6,000 lbs (2,721 kg)
Width	57 1/2" (1460.5 mm)

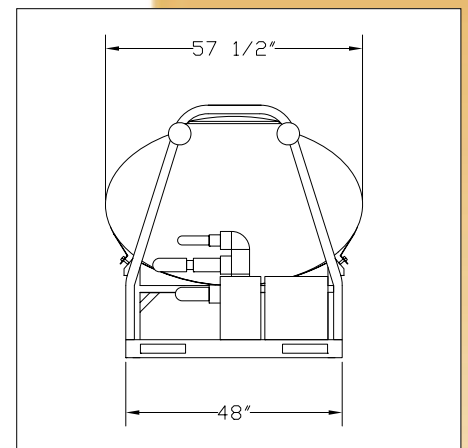
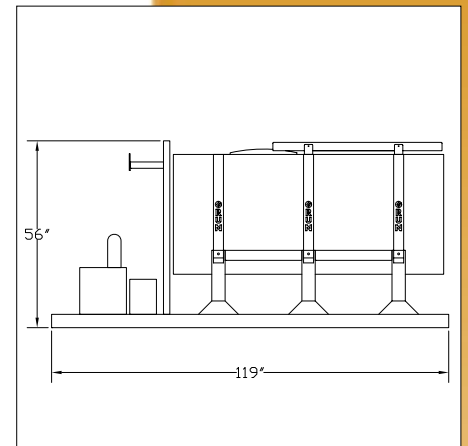

1070 Reno Avenue
 Modesto, CA 95351
 T 209.577.1430 • F 209.577.1573
 info@gruncompany.com

WWW.GRUNCOMPANY.COM